

# MV PRIMA DONNA

Dry Cargo / Minibulker

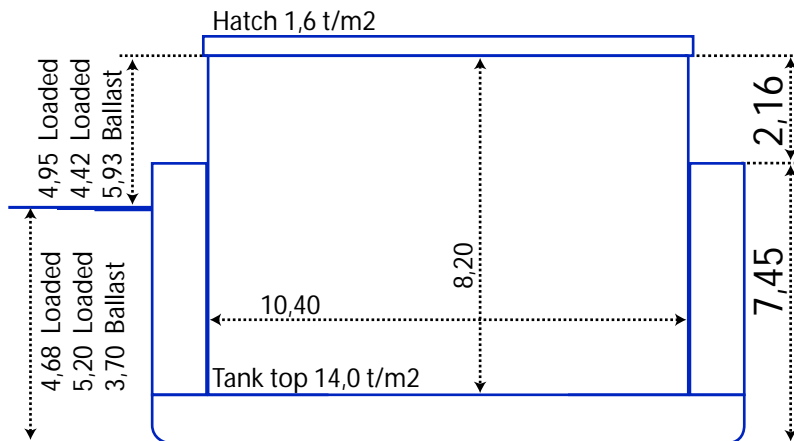
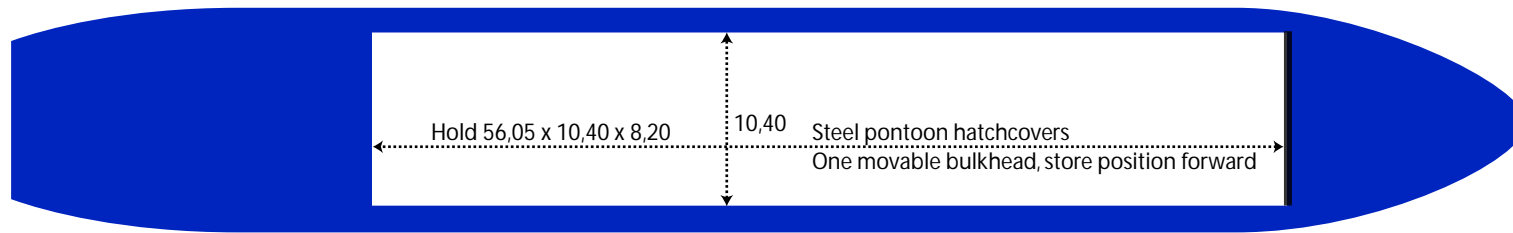
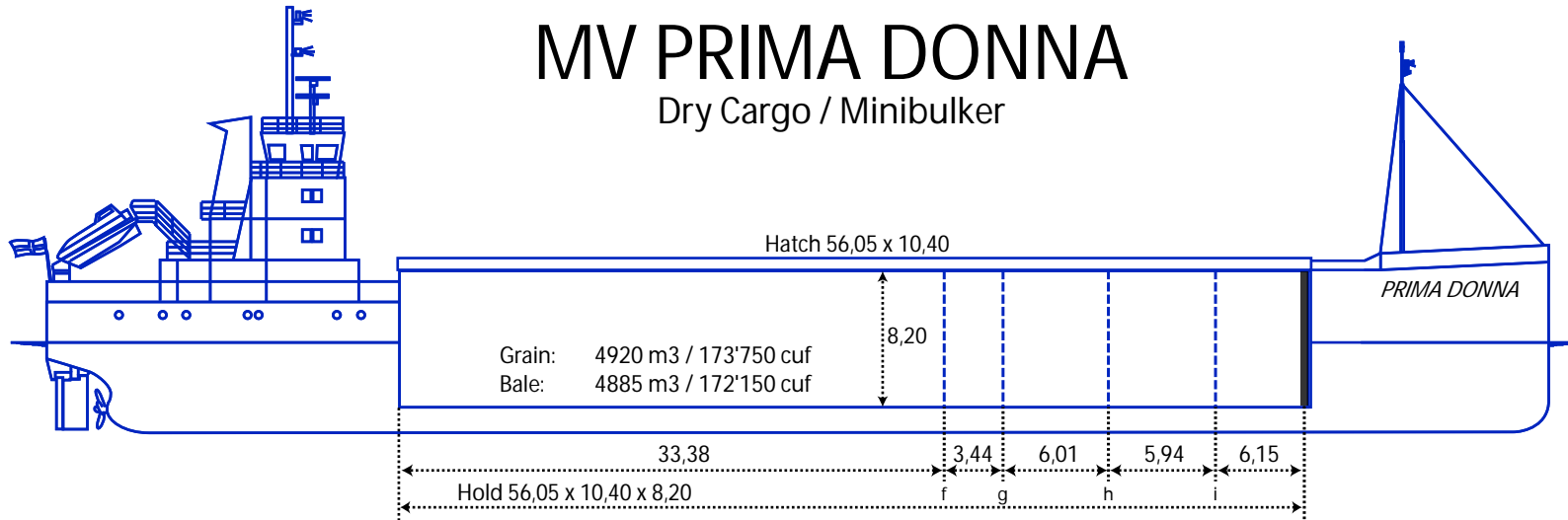

## Ship's contacts

Tel/GSM: +358-40-502 6610  
SatPhone/Iridium: +88-167-772 1870  
E-mail: donna@primas.fi

## Owner

Prima Shipping Oy Ab  
Tolkisvägen 773 info@primas.fi  
FIN-06750 TOLKIS chartering@primas.fi  
FINLAND www.primas.fi  
tel. +358195211100

## Particulars

Name: mv Prima Donna  
Call sign: OJPX  
IMO Nr: 8609606  
Flag: Finland  
Home port: Borgå  
Built: 1987  
Builder: J.J. Sietas Hamburg, DE  
Class: RINA  
Ice Class: Finnish-Swedish 1B and II  
P&I: Alandia

## Measurements

GT: 2673  
NT: 1240 (Ice 1B)  
DWT: 3004 (Ice 1B) / 3533 (Ice II)  
DWCC Summer: 3400  
DWCC Winter: 2750 (Ice 1B) / 3300 (Ice II)

## Main dimensions

LOA: 87,99  
LPP: 86,63  
Breadth: 12,80  
Depth mld: 7,45  
Draft: 4,70 (Ice 1B) / 5,20 (Ice II)  
Airdraft (loaded): 21,8  
Airdraft (ballast): 27

## Cargo hold

Grain: 4920 m3 / 173'750 cuf  
Bale: 4885 m3 / 172'150 cuf  
Containers: 108 TEU (hold) / 90 TEU (deck)  
Timber cap: 4400 m3  
Tank top: 14,0 t/m2  
Hatch: 1,6 t/m2

## Propulsion

Main Engine: Wärtsilä Vasa 6R32BC  
ME Output: 1860 kW  
Bowthruster: 180 kW  
Propeller: 4-blade CPP  
Speed (loaded): 10,5 kn  
Consumption: 6.5mt / day MGO at 10,5 kn

## Tankcapacity

Ballastwater: 1650 m3  
MGO: 230 m3